

## OPTICAL COMPARATORS

## HB400

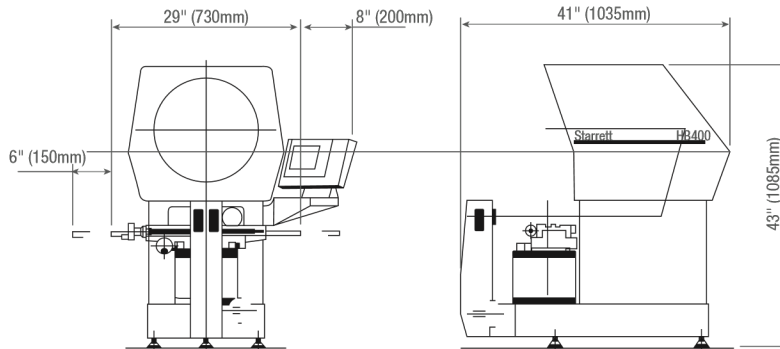

The HB400 horizontal optical comparator provides exceptional performance with a fully-usable 16" (400mm) diameter viewing screen, a 21" x 5" (530 x 125mm) workstage, 12" x 6" (300 x 150mm) of stage travel, and high 110lb workload capacity. Linear glass scales provide .00002" (0.5 $\mu$ m) of resolution. A bayonet lens socket accepts a choice of seven lenses or an OV2 Video Adapter for video edge detection (VED). Optional optical edge detection removes operator subjectivity in locating edges.



## FEATURES AND SPECIFICATIONS

- Digital protractor for accurate angular measurements (1' resolution) via Q-axis on readout
- Hard anodized aluminum top plate with cast iron intermediate and base plates
- 12" (300mm) horizontal travel by manual fine adjustment with quick release mechanism and 15° workstage helix adjustment
- 6" (150mm) vertical travel
- 24V, 150W profile illumination
- 24V, 250W fiber optic surface illumination
- Single lens mount with quick action lens change (lens not included); interchangeable and fixed 5x versions are available, call for quote
- Collimating condenser with yellow/green filter and provision to mount further accessories
- Measurement by means of a linear encoder (glass scale) on both X and Y axes
- Available with MetLogix™ M1 tablet, M2 PC-based touch screen software or Quadra-Chek® readout system
- Fixed retractable fiber optic surface illumination
- Extended workstage option



## WEIGHT AND DIMENSIONS

HB400	
Net Weight	320lbs 145kg
Gross Weight	385lbs 175kg

For more information please see the Options and Specifications table at the end of this section.

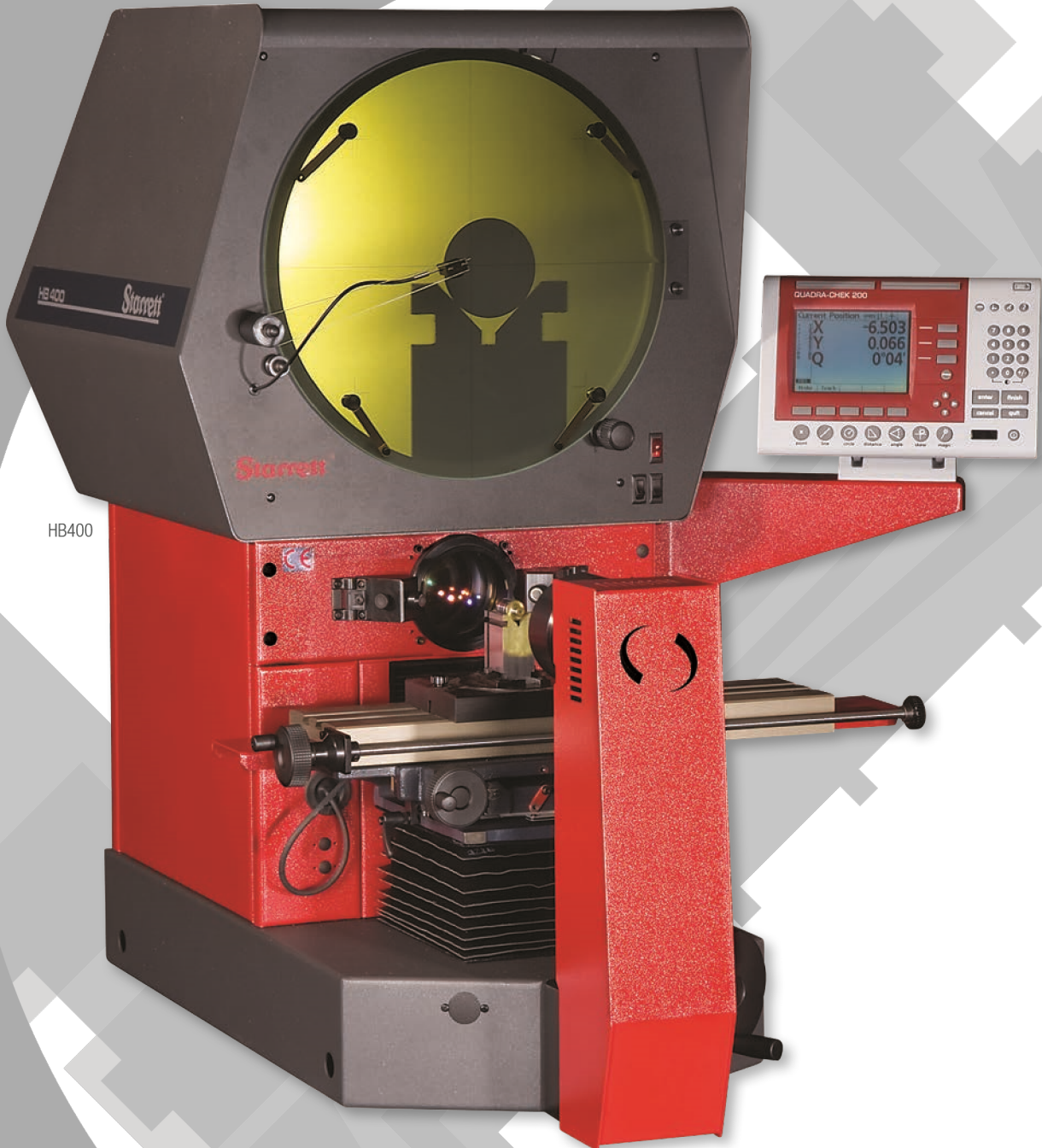

HB400

## HB HORIZONTAL BENCHTOP

